

USE AND MAINTENANCE MANUAL

ROTARY TILLER TYPE "URT"

URT E-D

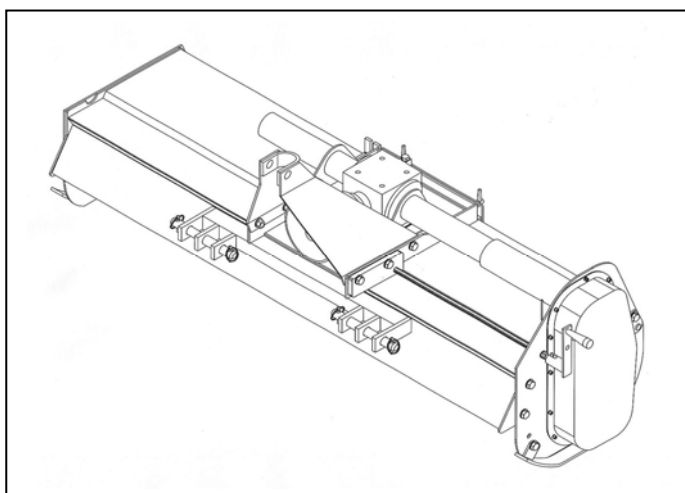

URT HF

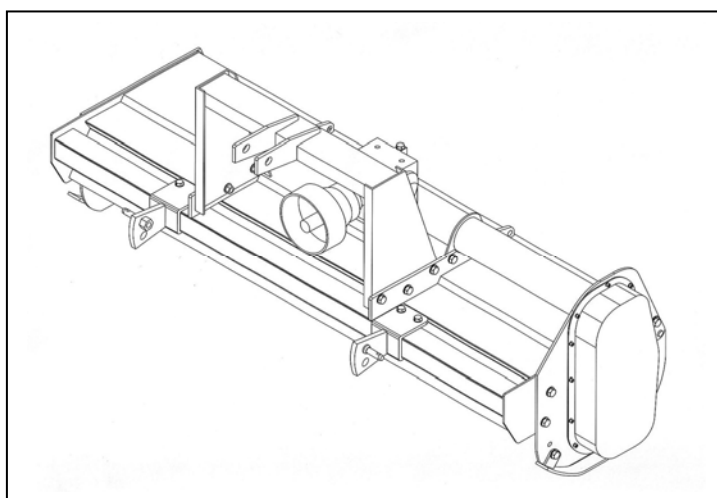

TECHNICAL SPECIFICATION

CHARACTERISTICS PER MODEL

Model	Type	Version		Power		Working width		Weight		Working depth		Maximum displacement (D Version)		Total width		Nr. of hoes		
		Fixed	Offset	HP	KW	Cm.	Inch.	Kg.	Lbs.	Cm.	Inch.	Cm.	Inch.	Cm.	Inch.	N. flange	4 hoes/fl	6 hoes/fl
URT-E/D	96		X	15-35	11-26	96	38	175	335	18	7	16	6	108	42	5	20	30
	114		X	15-35	11-26	114	46	198	380	18	7	21	9	126	49	6	24	36
	132		X	20-40	15-30	132	53	211	410	18	7	26	11	144	56	7	28	42
	150		X	20-40	15-30	150	60	226	454	18	7	30	12	162	63	8	32	48
	168		X	30-50	15-37	168	67	250	454	18	7	30	12	180	71	9	32	54
URT-HF	168	X		40-60	30-44	168	67	252	555	19,8	8			180	71	9	36	54
	186	X		40-60	30-44	186	75	269	592	19,8	8			198	79	10	40	60
	204	X		50-65	37-48	204	80	330	727	19,8	8			216	85	11	44	66
	222	X		50-65	37-48	222	87	370	814	19,8	8			234	92	12	48	72

SPARE PARTS AND OPTIONS

URT-E/D MECHANISMS

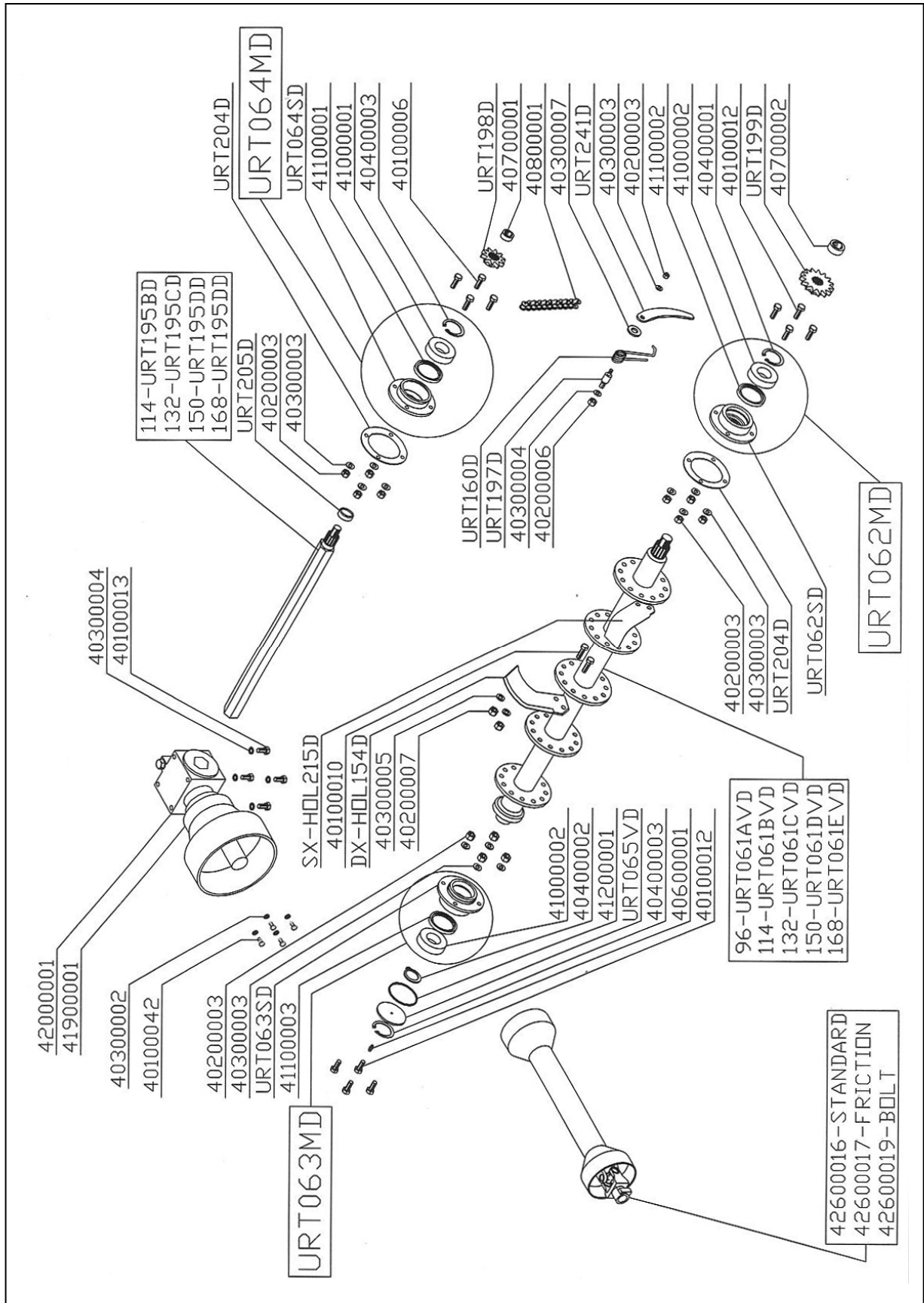

URT-HF MECHANISMS

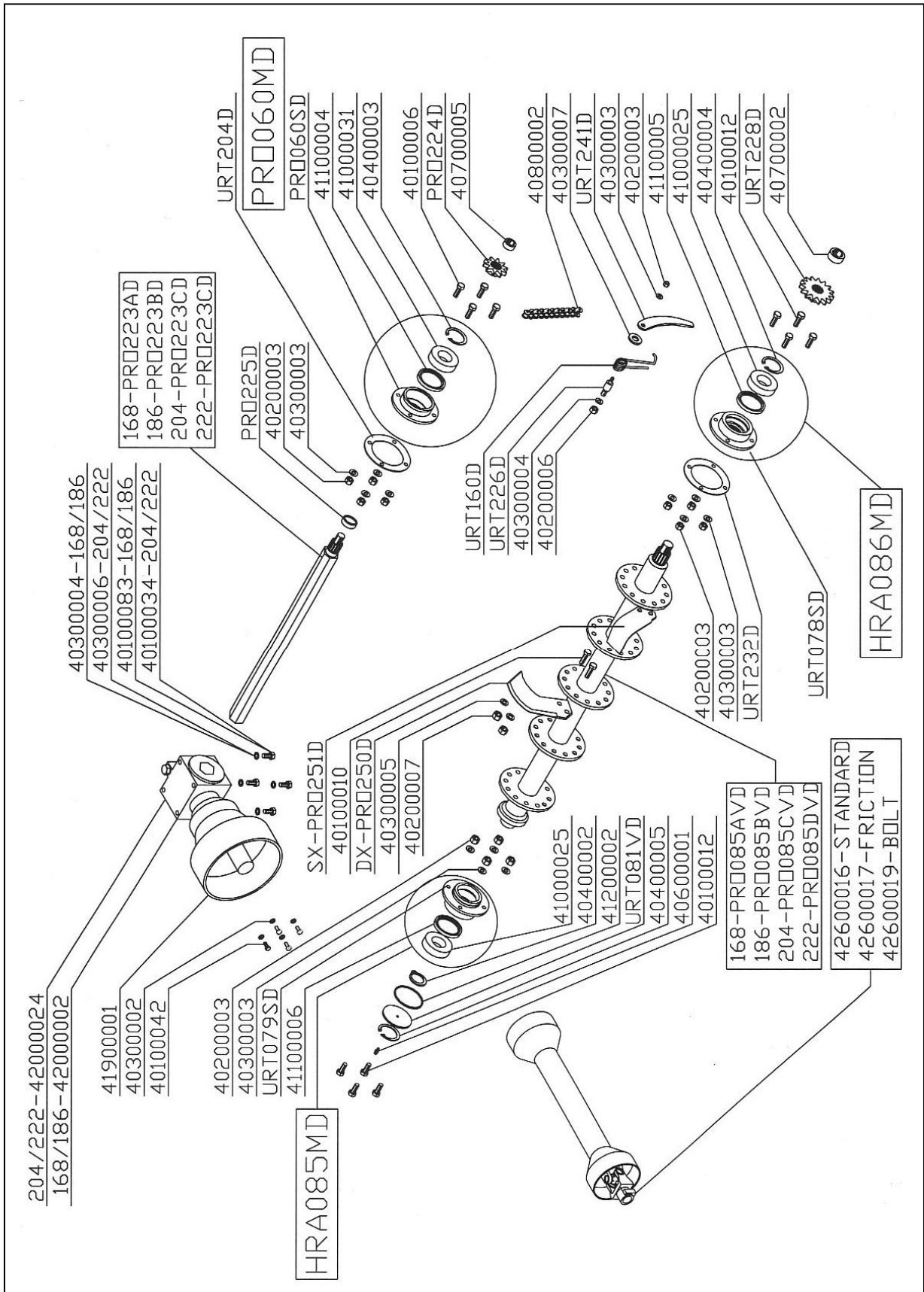

URT-E/D FRAME COMPONENTS

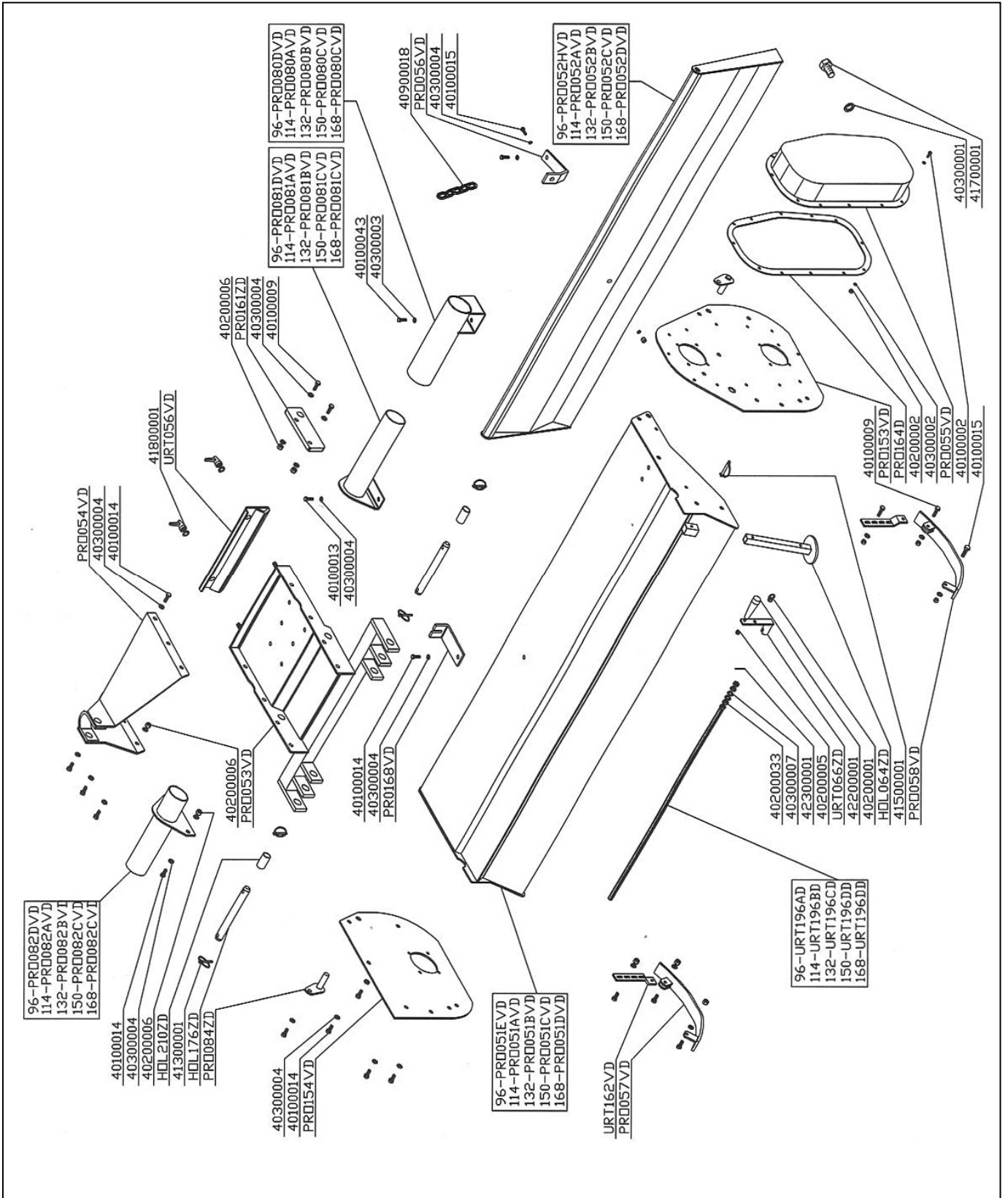

URT-HF FRAME COMPONENTS

